



SANDOR QUAD-ESA SMA

DUAL OPTIC

Installation manual

INDEX

1	COMPONENTS	Pag. 3
2	MOUNTING EXAMPLES	Pag. 4
	MOUNTING WITH BRACKETS	Pag. 5
3	INSTALLATION EXAMPLES	Pag. 6
4	CABLES AND CABLING	Pag. 7
	CONNECTION AND HEATING SETTING	Pag. 8
5	OPTICAL CONFIGURATION	Pag. 9
) TX OPTICAL	Pag. 9
) RX OPTICAL	Pag. 10
) 3 RX/TX SETTINGS	Pag. 11
) 2 RX/TX SETTINGS	Pag. 11
6	COLUMN ALIGNEMENT	Pag. 12
7	CALIBRATION THROUGH SMA SYSTEM	Pag. 13
8	CALIBRATION WITH PARALLEL BEAMS	Pag. 17
9	CALIBRATION WITH CROSSING BEAMS	Pag. 18
10	SETTINGS AND PROGRAMMING SCHEDA QUAD TX	Pag. 19
) DIP SWITCHES DESCRIPTION	Pag. 20
) LED DESCRIPTION	Pag. 20
) CONNECTOR DESCRIPTION & FUNCTIONALITY	Pag. 20
11	SETTINGS AND PROGRAMMING QUAD RX	Pag. 21
) DESCRIPTION DIP SWITCHES	Pag. 22
) DIP SW 1	Pag. 22
) DIP SW 2	Pag. 22
) LED DESCRIPTION	Pag. 23
) CONNECTOR DESCRIPTION & FUNCTIONALITY	Pag. 23
12	RESPONSE TIME SETTINGS	Pag. 23
13	TECHNICAL CHARATTERISTICS	Pag. 24

Installation recommendation

- *Verify that the beam tower is fully watertight once the cover and end caps have been correctly filled at the end of the installation.*
- *Use the cable glands supplied on the tower for all cabling must pass through the lower end cap using the cable glands supplied. The missed used of proper accessories decrease the IP grade protection of the tower.*
- *Avoid any type of obstruction between the transmitter and receiver.*
- *Avoid installing the receivers beams in a position where direct sunlight, at the same angle as the receivers beams, can enter directly into optics especially at sunset and sunrise*
- *Do not install multiple beams where the transmitter beam can interfere with other receiver beams. It is always better place either transmitter or receivers back to back.*

1 MAIN COMPONENTS LIST

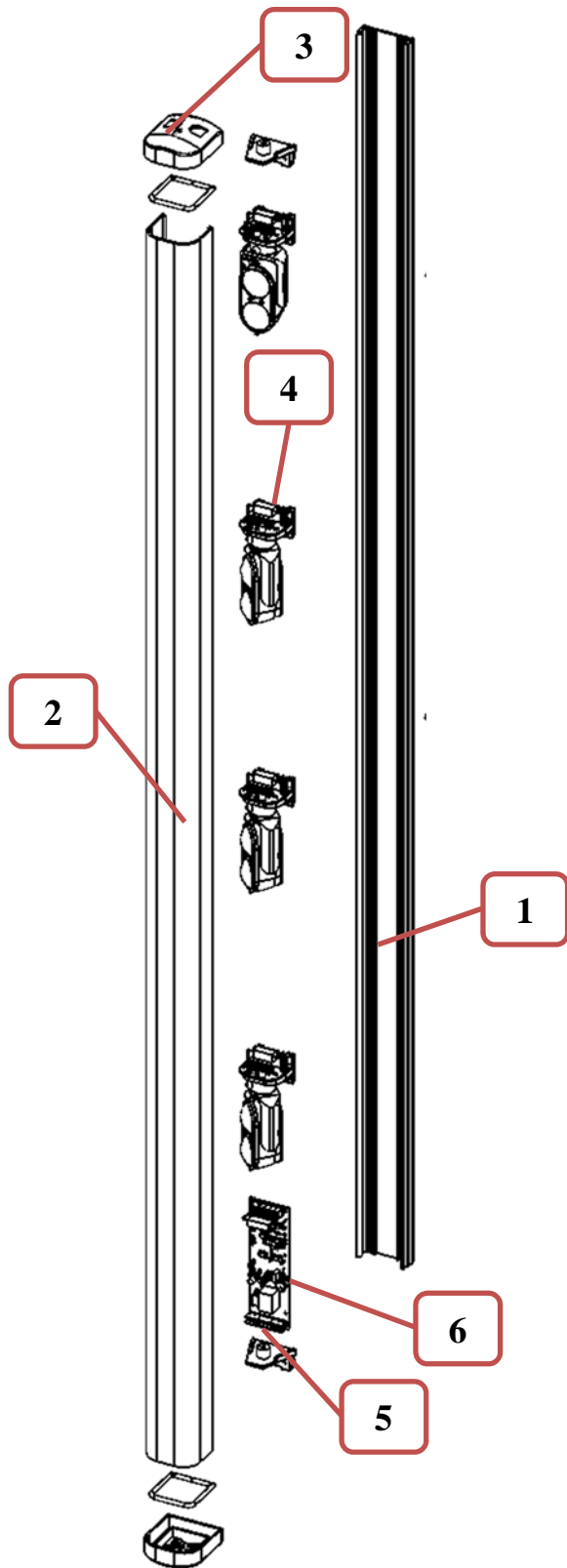

N° Parte	Descrizione
1	Aluminium profile
2	IR cover
3	Caps
4	Opticals RX/TX
5	Terminals board
6	Mother board

2 MOUNTING SAMPLES



**Pole
mounting
with
SAN/PL**

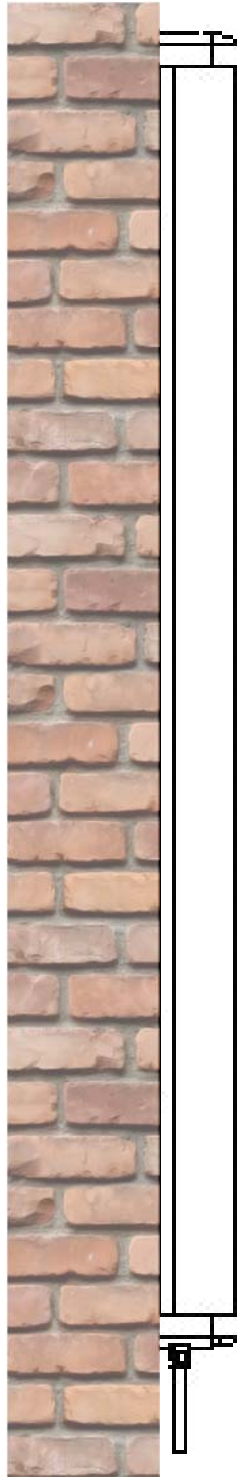

**Wall
mounting
with
SAN/SD**

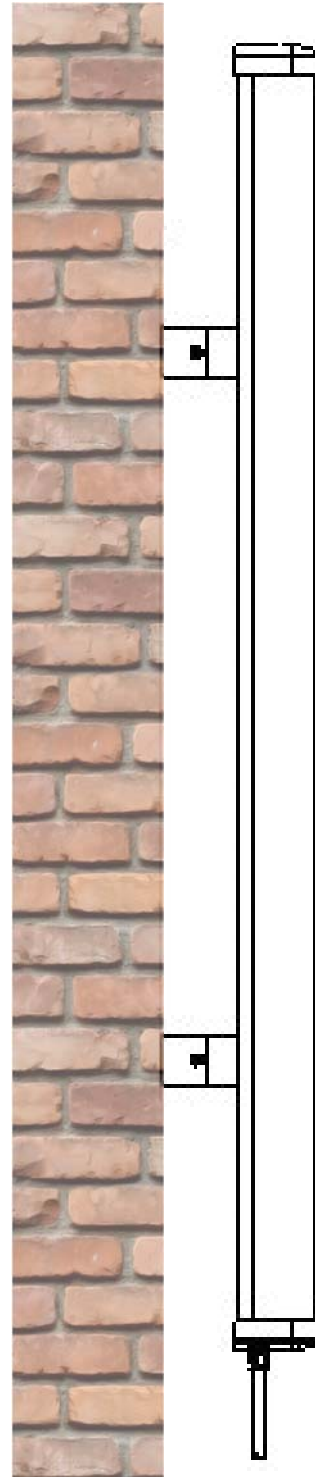

**Wall
mounting
with
SAN/PL**

MOUNTING WITH BRACKETS

**Insert the bracket
on the back**

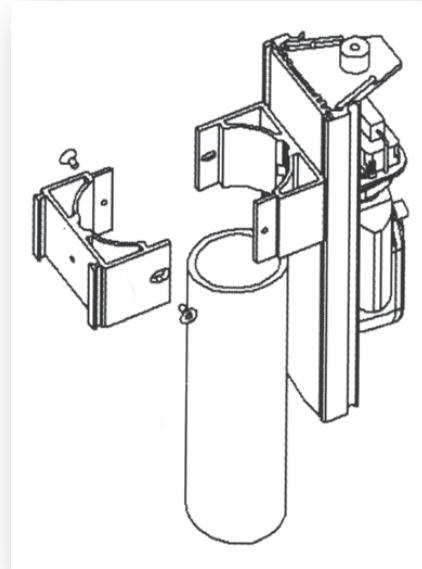
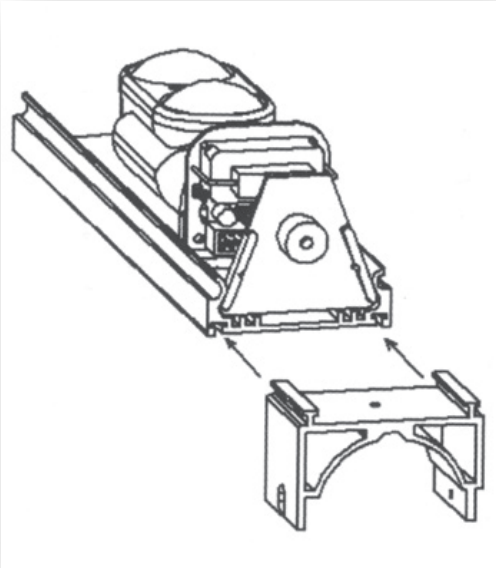

**Pole
mounting
with
SAN/PL**

**Diameter pole
max 48 mm**

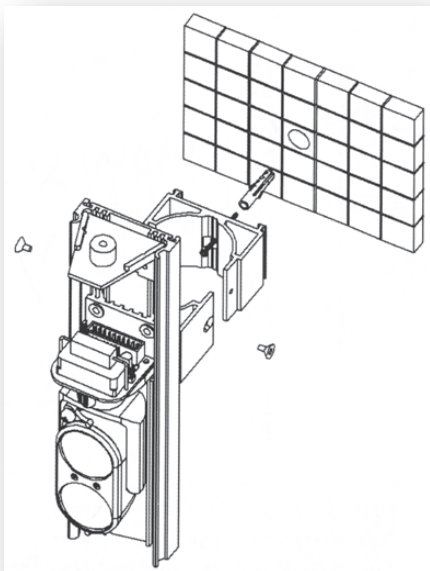

**Wall mounting with
SAN/PL**

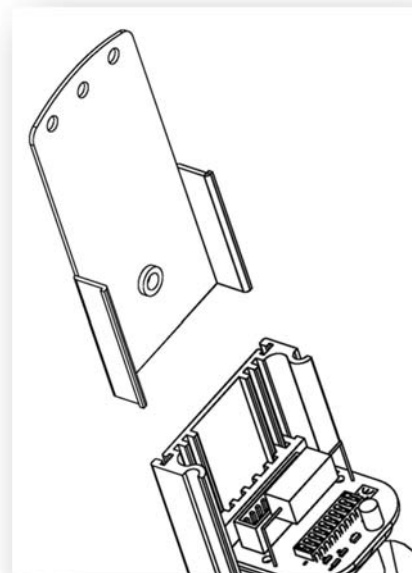

**Wall mounting with
SAN/SD**

N.B.: we recommend the use of the brackets SAN / PL on the wall when you place the protection of gates (windows, doors, ...) along the wall to avoid small obstacles (hinges, edges of window sills, ...) that could create signal attenuation.

3 INSTALLATION EXAMPLES

For an installation to control the perimeter install the barriers as shown:

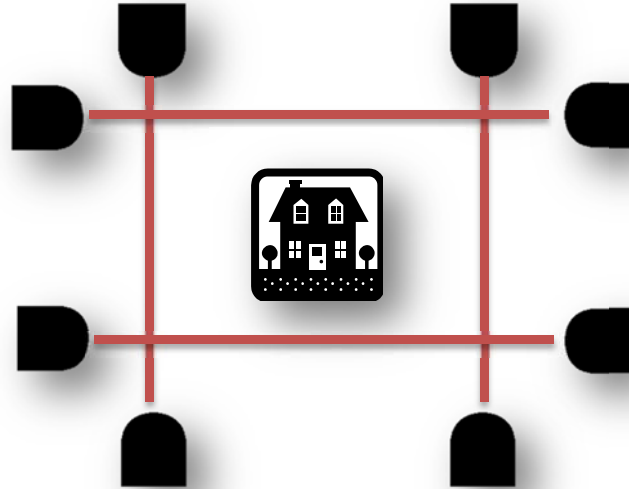

For an installation of barriers overlapped position the barriers as well as in the figure:

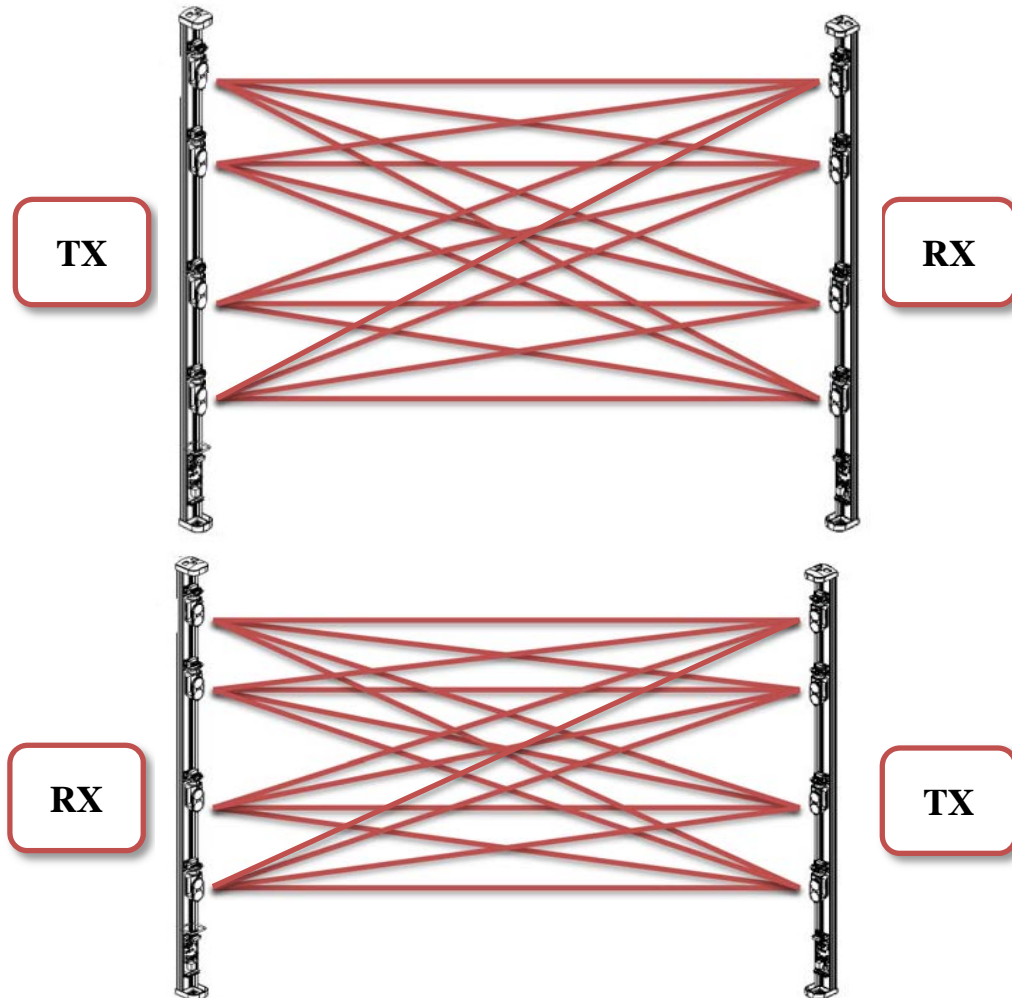

4 CABLES AND CABLING

The wiring requires to SEPARATE the power cable 12Vdc (ex. 2x0.5 + Nx0.22), to the power cable for heaters 24Vac (ex. 2x0.75) to prevent input of disorders of the AC voltage on the barrier.

N.B. is absolutely necessary to shield the cable that provides 12 Vdc power supply and put the metal braid to ground.



The cable size depends on the consumption of the columns and the resistance of the cable to the distances involved.

The table shows the cable sections and the relative distances to which they provide optimum performance using the supplier LAR22 (12Vdc - 2,5A / 24V AC-300W) and a barrier SANDOR QUAD / ESA SMA.

Cable section	12Vdc	24Vac
0,5 mm ²	165 m	35 m
0,75 mm ²	245 m	50 m
1,5 mm ²	490 m	100 m
2,5 mm ²	820 m	165 m
4 mm ²	1310 m	265 m
6 mm ²	1975 m	400 m

N.B. THE LAR22 IS NOT WATERPROOF, MUST BE PLACED INSIDE A LOCAL OR PLACED IN A SEALED CONTAINER FOR USE OUTSIDE.

Is possible use the power supplier LAR18 (12Vdc – 0,9A / 24VAC-60W) to supply a single column.

CONNECTION AND HEATING SETTING

The power of the heaters is by default set to 24 Vac, but you can set it to 12 Vdc repositioning the jumper on both RX and TX mother boards and on each optical as shown.

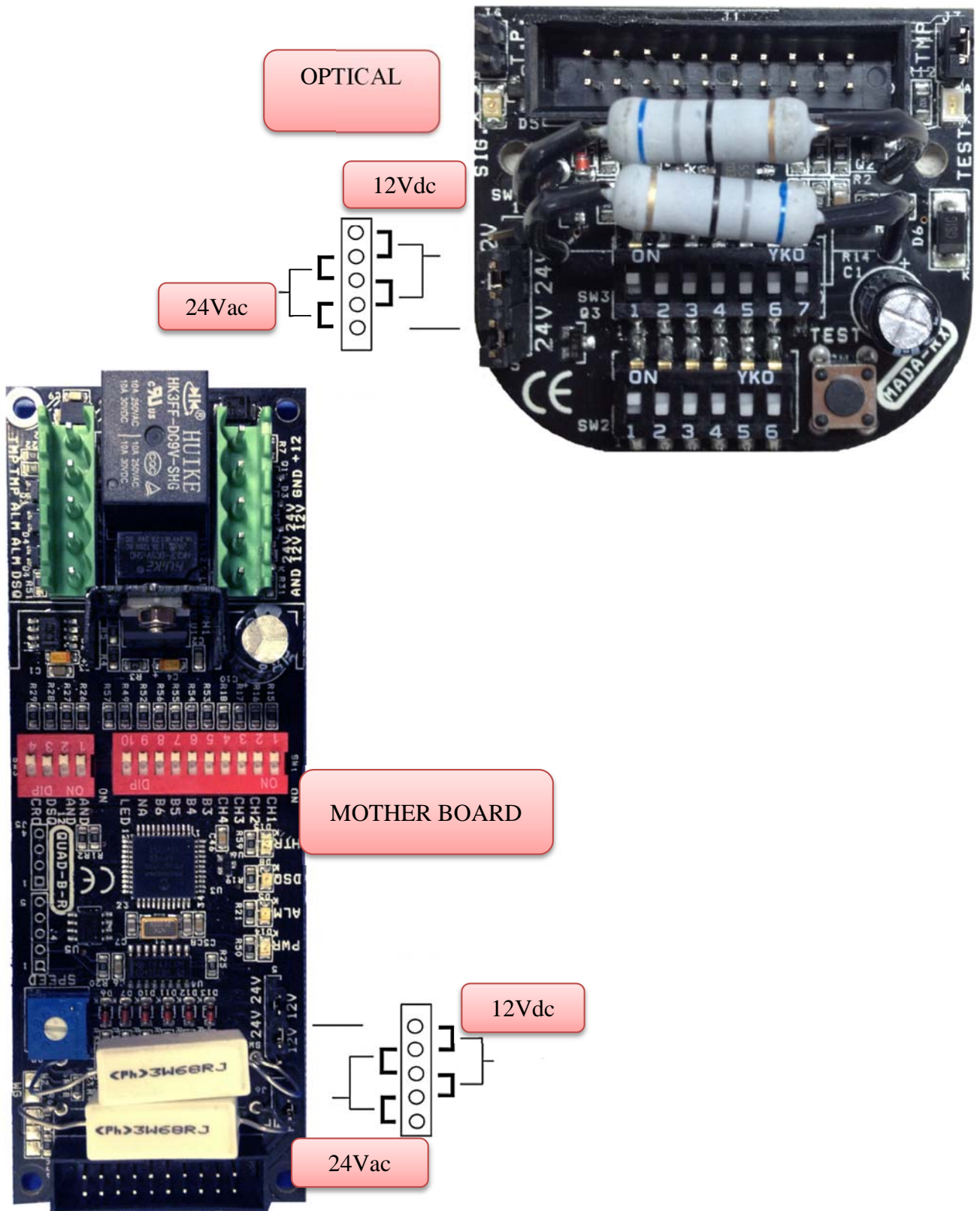

5 OPTICAL CONFIGURATION

TX OPTICAL

TAMPER

SUPPLY LED

HEATERS SUPPLY

24Va

12Vdc

	1	2	3	4	5	6	7	1	2	3	4	5	6
TX1	█	█	█	█	█	█	█	█	█	█	█	█	█
TX2	█	█	█	█	█	█	█	█	█	█	█	█	█
TX3	█	█	█	█	█	█	█	█	█	█	█	█	█
TX4	█	█	█	█	█	█	█	█	█	█	█	█	█
TX5	█	█	█	█	█	█	█	█	█	█	█	█	█
TX6	█	█	█	█	█	█	█	█	█	█	█	█	█

ESA MODEL

To test the functionality of optics TX put ON the DIP 7 and see the activation of the power LED. Set SW4 to supply of the heaters. 24V (standard) or 12V. The voltage can be AC or DC.

NB: The settings relating to addresses are already set to Default.

RX OPTICAL

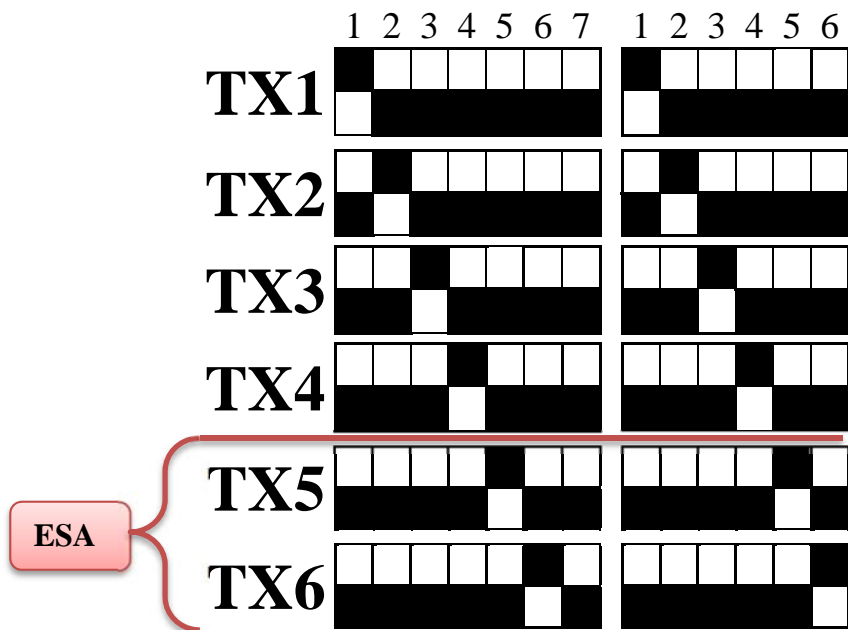
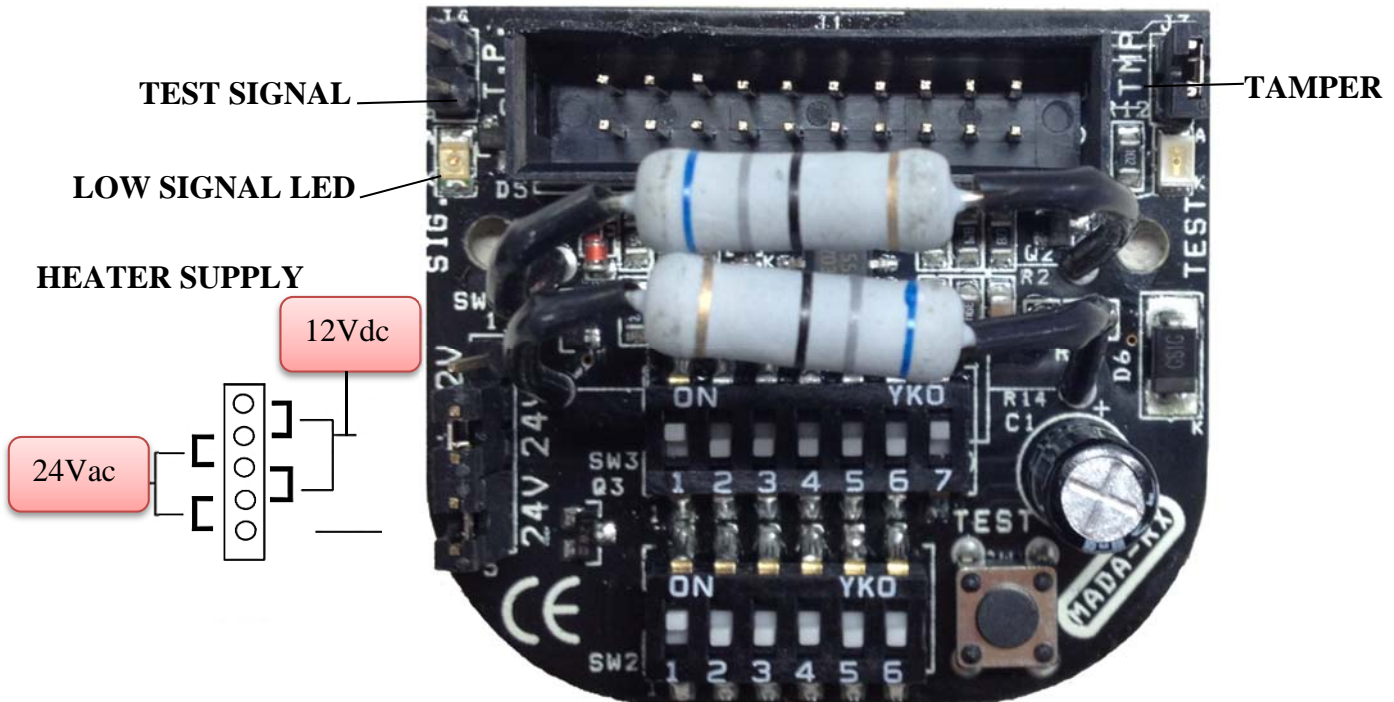

To test the functionality of optics TX put ON the DIP 7 and see the activation of the power LED. Set SW4 to supply of the heaters. 24V (standard) or 12V. The voltage can be AC or DC. In the J4 jumper reads the value of the signal in volts.

NB: The settings relating to addresses are already set to Default.

3 RX / TX SETTING

The setting of the DIP SWITCH on optical is amended as follows:

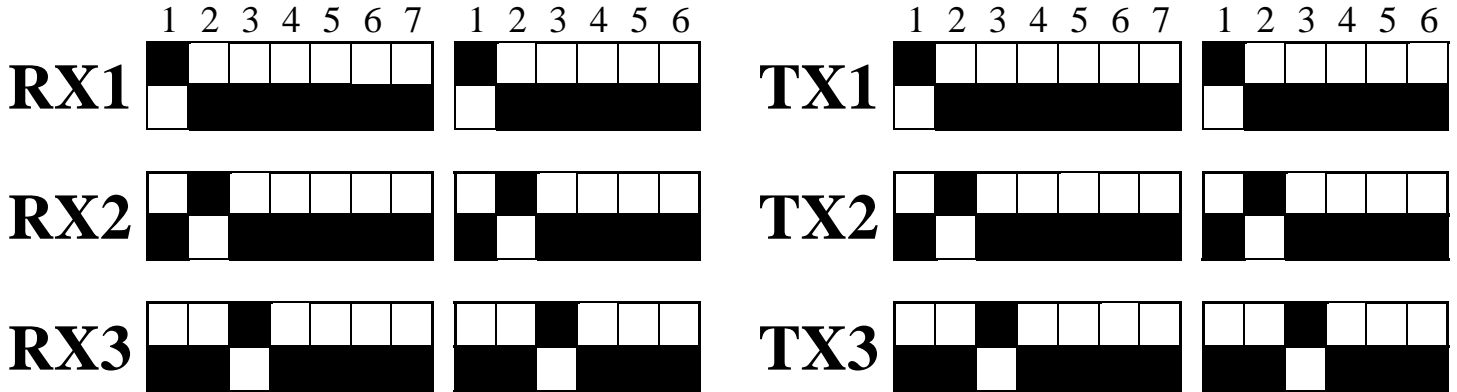

It should be set to ON the DIP on the motherboard RX exclusion 4

2 RX / TX SETTING

The setting of the DIP SWITCH on optical is amended as follows:

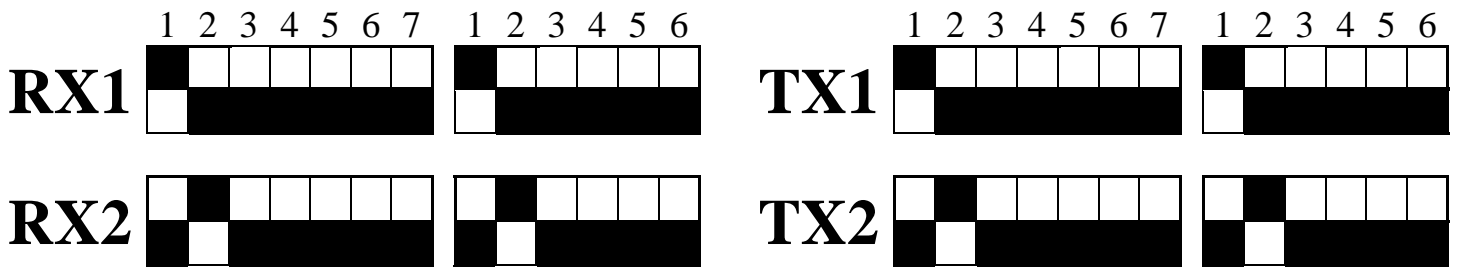

It should be set to ON the DIP on the motherboard RX exclusion 3 + 4

6 COLUMN ALIGNEMENT

For proper alignment, once the barriers are installed, orient the optical of transmitters and receivers in the direction of each other by adjusting the lens holder horizontally through the manual movement after loosening the locking screw on the joint, and vertically through the front screw on the left side of the lens.

Vertical adjustment

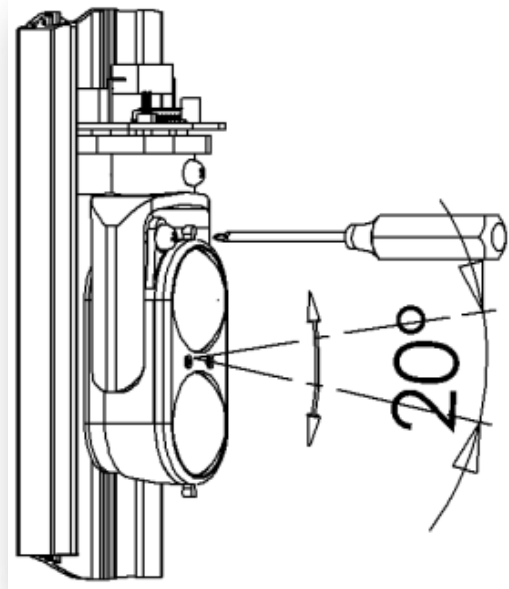

Horizontal adjustment

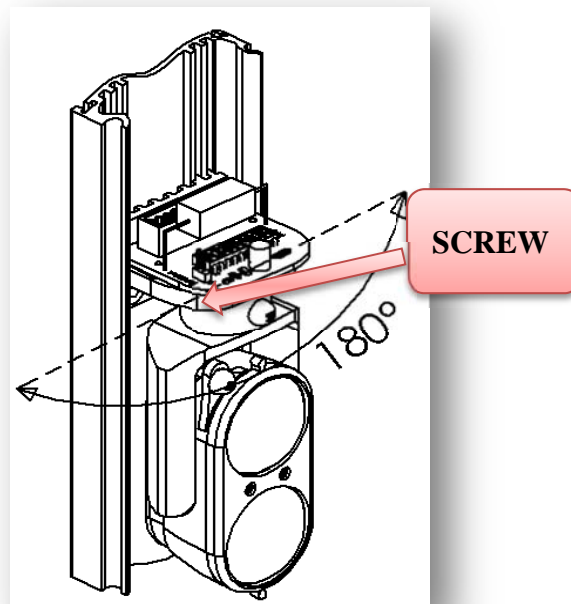

N.B.: FASTEN THE UNLOCKING SCREW AFTER THE ADJUSTMENT

7 CALIBRATION THROUGH SMA SYSTEM

You can improve the calibration through the use of the supplied filter

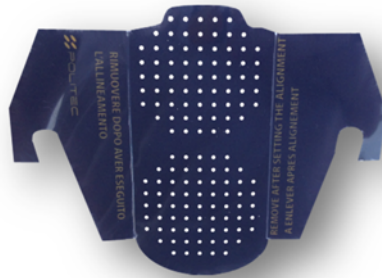

1) Fold the device according to the preset creases

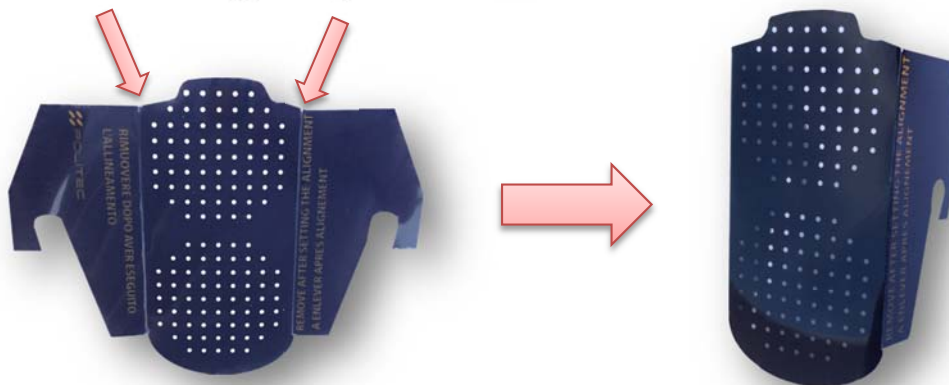

2) Place the filter in front of the optics TX placing the two hooks on the pins of the fork optics to refine the search for the signal alignment with critical conditions.



You simply apply the filter only on the TX, it is not necessary to repeat the operation on the RX also.

3) Start the alignment of the transmitter is on the barrier by checking the position of the DIP switch 7 to ON and activating the TEST optics TX (1 or 2 or 3 or 4), by pressing the dedicated button for about 3 seconds until the orange LED TEST will lit up.

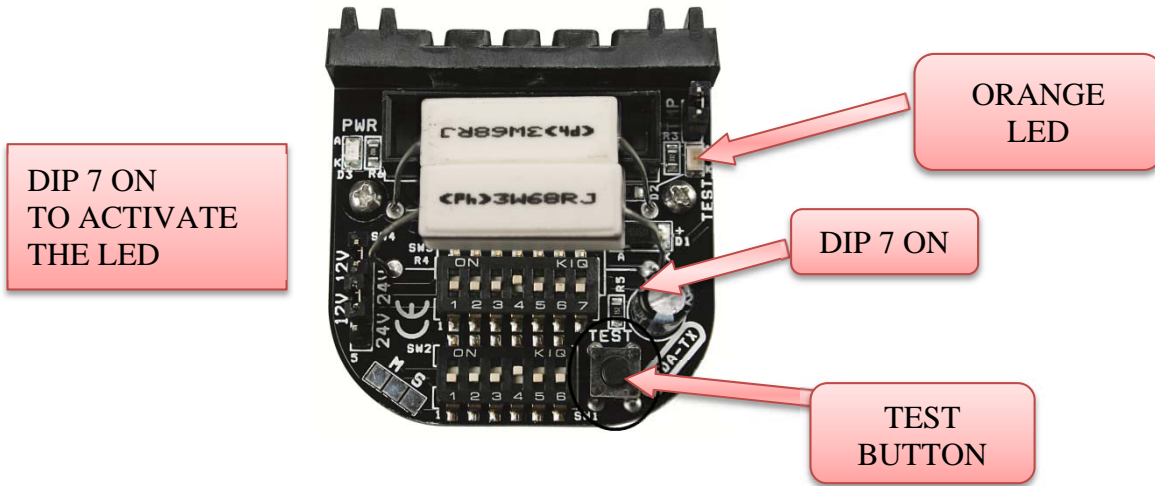

- 4) Place in the corresponding optical TEST (1 or 2 or 3 or 4) on coral receiver, checking the position of the DIP switch 7 to ON and pressing the dedicated button for 3 seconds until the BUZZER and the LED TEST turns ON, (with high brightness)

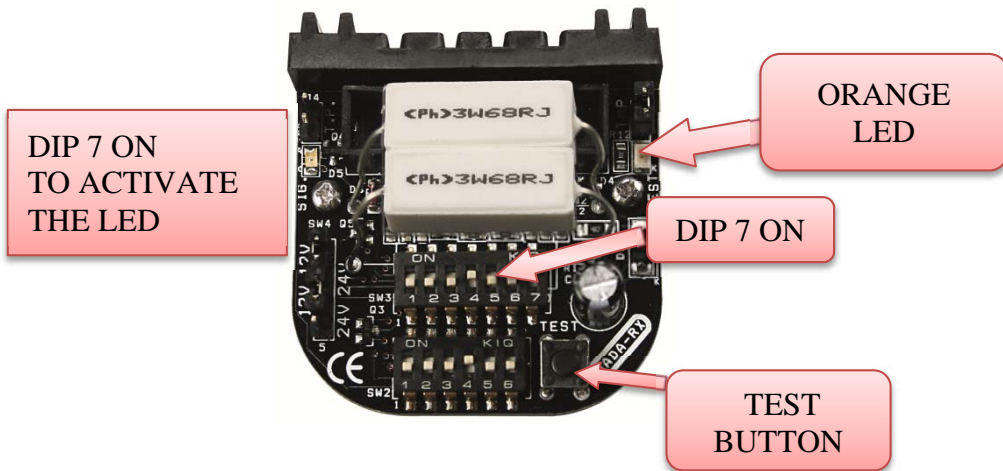

- 5) Through the TRANSMITTER lens shifts, find the maximum optical alignment based on the Buzzer and LEDs (with high brightness), the increase in the frequency of flashing (until the LEDs is fix on and the whistle of the corresponding BUZZER) indicate a better ALIGNMENT.



- 6) With a FULL rotation on the horizontal RX lens, is carried out the SCANNING of the optical signal.

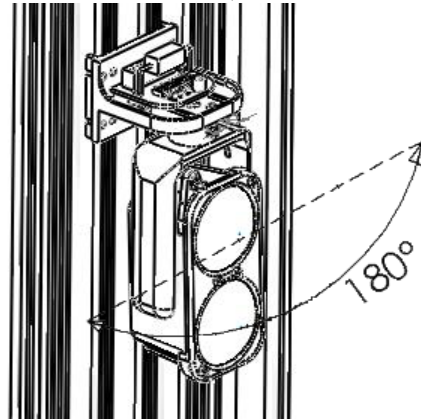

- 7) Rotating the lens RX find the maximum value of ALIGNMENT corresponding to the LEDs (with high brightness) FIXED and the whistle of the BUZZER CONTINUOUS.
- 8) Exit the function of by repressing the ALIGNMENT TEST button for about 3 seconds on both optics (TX-RX) making sure that the orange LED TEST is shown in original condition.
- 9) When finished, remove the shade that acts as a dampener, having the certainty of having found the optimum value.



10) Set the DIP switch 7 to OFF to ALL OPTICAL if you want to turn off the LEDs.

DIP 7 OFF
TO SWITCH
OFF THE LED

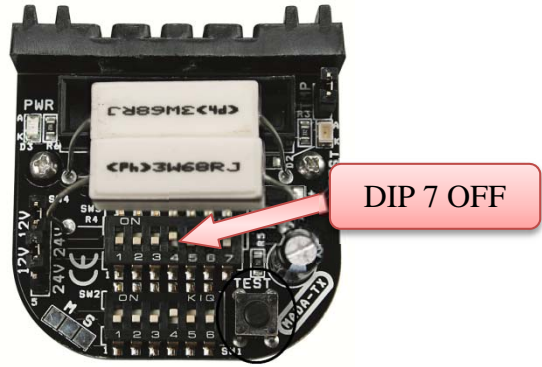

NB: you can SEE the calibration value through the multimeter on each optical receiver. For this procedure, you must have the pair of lenses (TX-RX) in TEST.

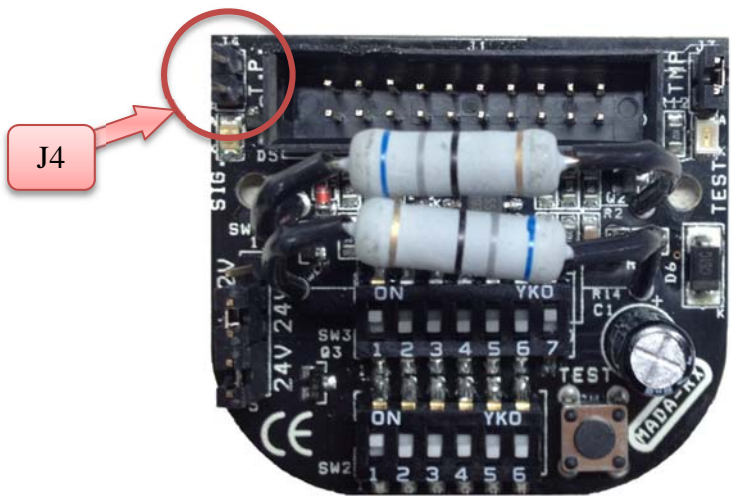

8 PARALLEL BEAM CALIBRATION



Put in TEST the optical TX1 and RX1 if present (see p.10-11), and proceed with the calibration as explained above.



Put in TEST the optical TX2 and RX2 if present (see p.10-11), and proceed with the calibration as explained above.



Put in TEST the optical TX3 and RX3 if present (see p.10-11), and proceed with the calibration as explained above.

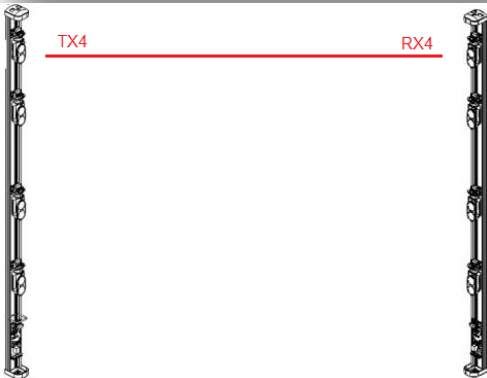

Put in TEST the optical TX1 and RX1 if present (see p.10-11), and proceed with the calibration as explained above.

N.B.: during the testing phase of an optical transmitter the other TX not in test are switched off automatically.

9 CALIBRATION WITH CROSSED BEAMS

To activate move the DIP. 4 ON of the board QUAD RX (Chapter 10).

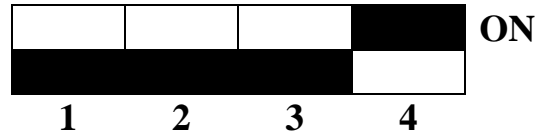

Perform the alignment putting on test one optical per time

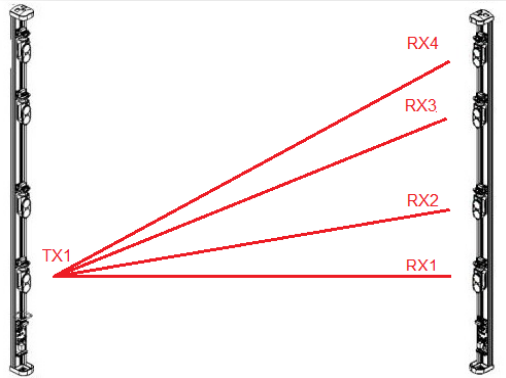

Activate the TEST for TX1 and check for proper alignment of optics at a time using the TEST on RX1 and AFTER RX2, RX3, RX4 making sure that TX1 still aligned with RX1.

In the same way TEST the TX2, TX3, TX4,

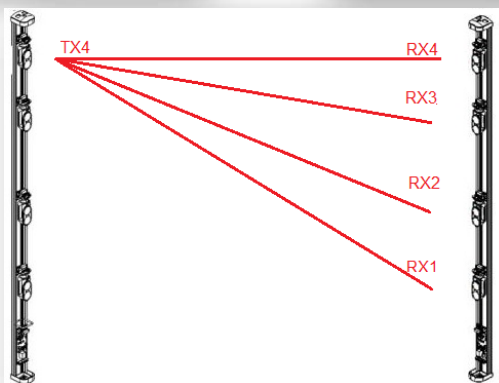
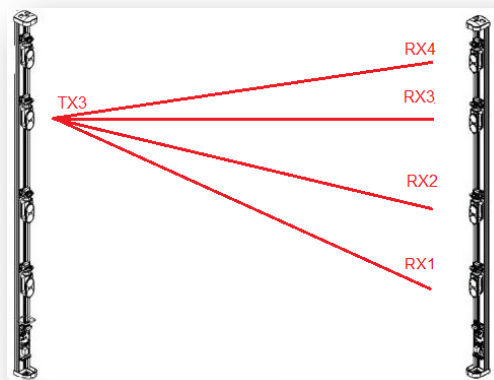
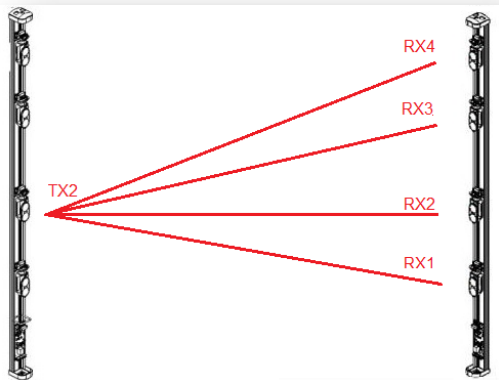

NB: It requires a minimum distance of at least 8 meters so that the first optical receiver see the last transmitter and vice versa. Especially if you use the ESA configuration with 6 optical receivers, and 6 optical transmitters.

10 SETTING AND PROGRAMMING QUAD TX

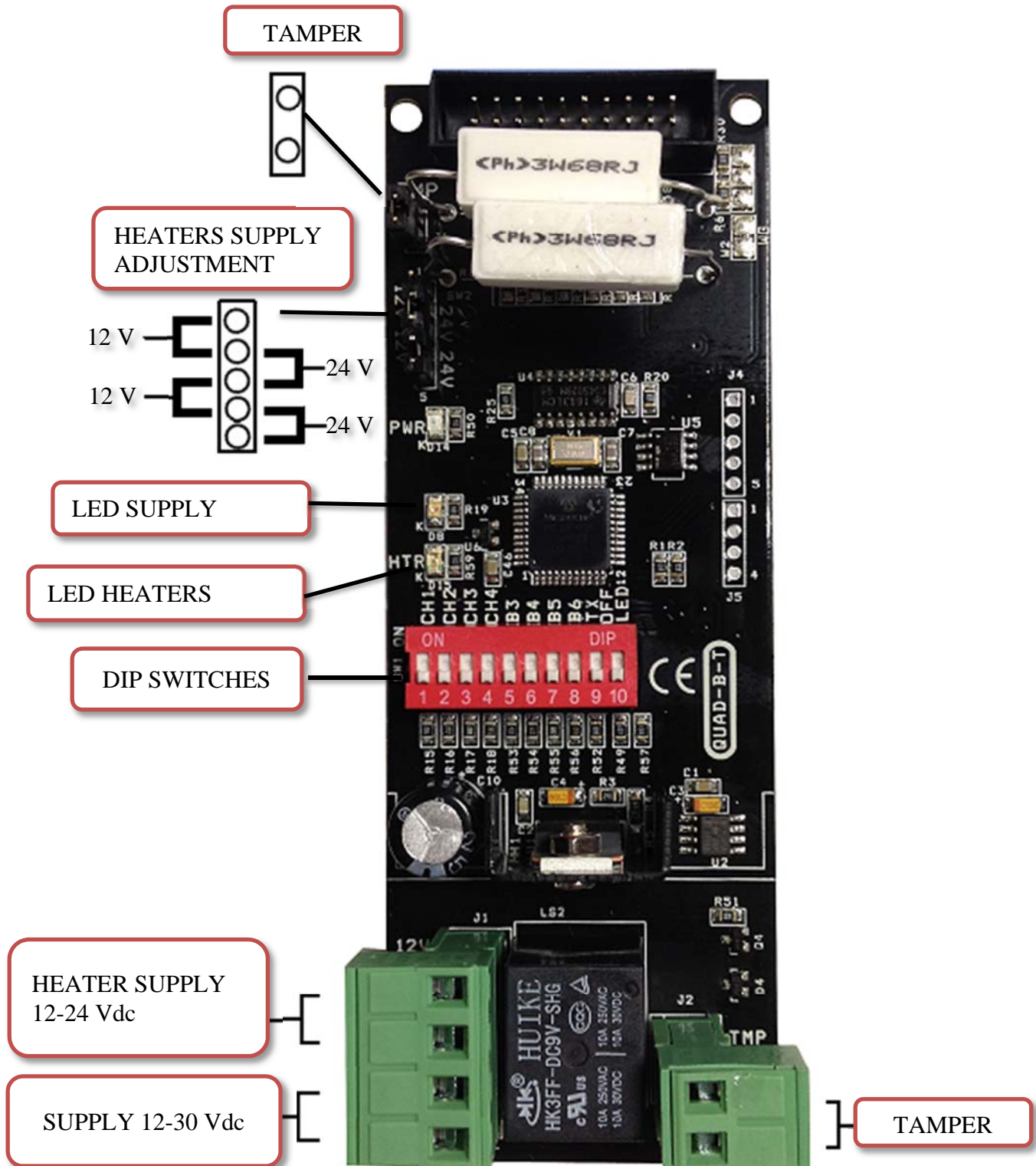

DIP SWITCHES DESCRIPTION

The board has a single serie of dip switches for the configuration of the transmitter

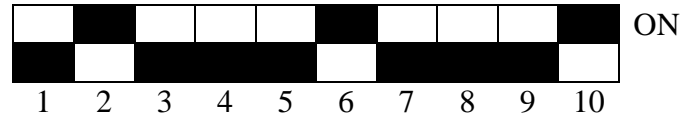

1	Tx channel 1
2	Tx channel 2
3	Tx channel 3
4	Tx channel 4
5	BEAM 3: 3 TX active
6	BEAM 4: 4 TX active
7	BEAM 5: 5 TX active (ESA)
8	BEAM 6: 6 TX active (ESA)
9	TX OFF: all TX OFF
10	LED: All led active

LED DESCRIPTION

I led saranno accesi solo se il dip switch 10 è impostato su ON.

LED POWER	Indicates the mother board ON
LED RISCALDATORI	Indicates the status of heaters. It will be activated if the temperature inside the barrier become below 18°C

CONNECTORS DESCRIPTION AND FUNCTIONALITY

The connector has:

- Supply 10-30Vdc
- Tamper output
- Supply 12-24Vac-dc for heaters on board QUAD-ESA and on the optical.

On the card is provided an input for the tamper. In case of absence of that close the input with a jumper

11 SETTING AND PROGRAMMING QUAD RX

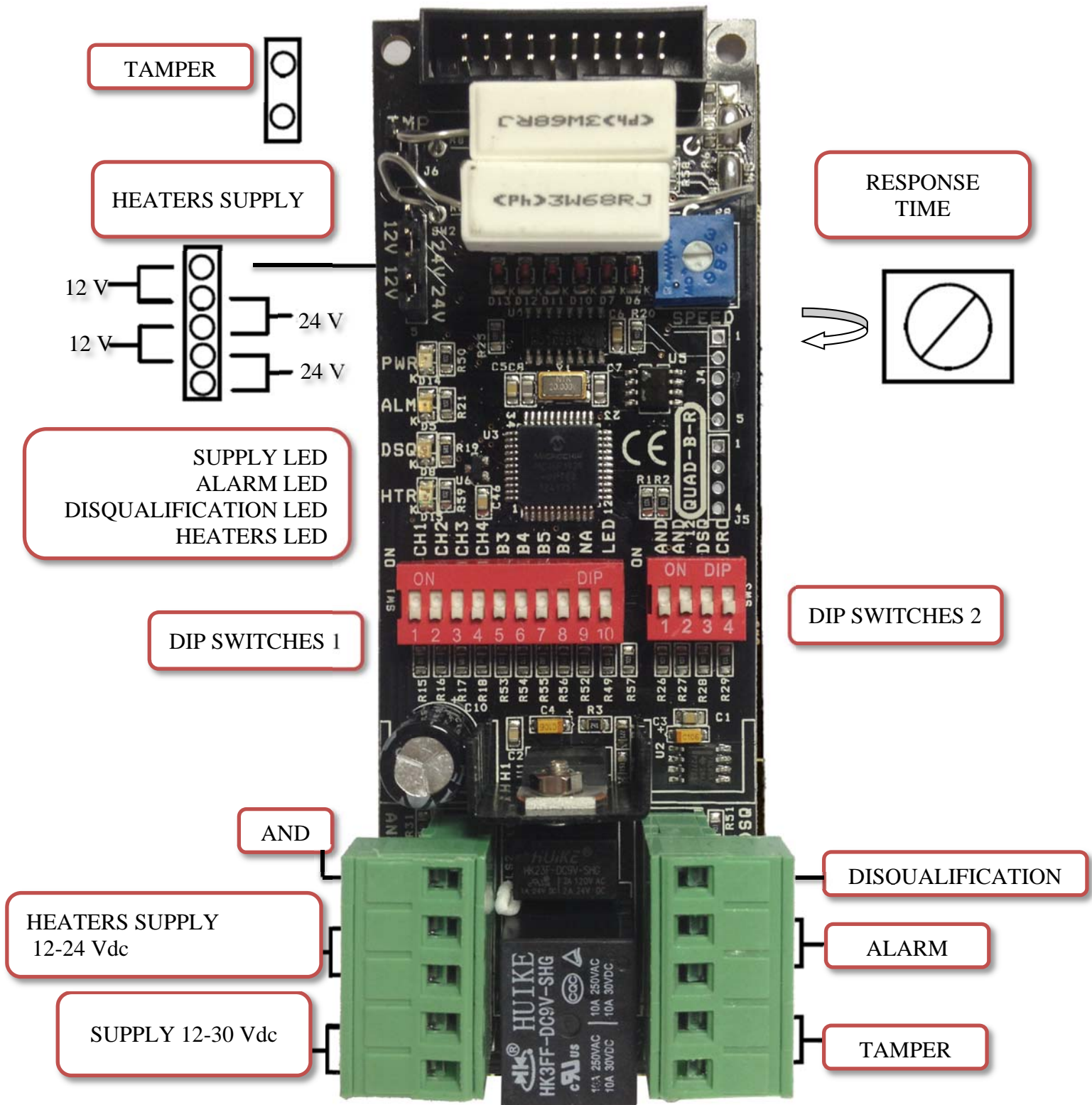

DIP SWITCHES DESCRIPTION

The card has two series of dip switches where you can set different configurations:

DIP SW1

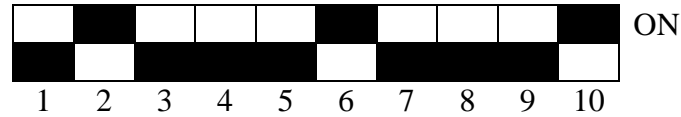

1	Tx channel 1
2	Tx channel 2
3	Tx channel 3
4	Tx channel 4
5	BEAM 3: 3 TX active
6	BEAM 4: 4 TX active
7	BEAM 5: 5 TX active (ESA)
8	BEAM 6: 6 TX active (ESA)
9	Relay N.O.: if ON, the alarm relay will be N.O. otherwise it will be N.C
10	All led active

DIP SW2

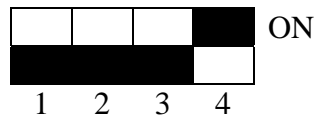

1	AND	The Barrier goes in alarm only if at least 2 beam are interrupted
2	AND 1-2	The AND condition is only for the beams 1 & 2
3	DISQ	Disqualification activated
4	CRO	If ON the system will operate with crossed beams

LED DESCRIPTION

The led are active ONLY if the dip 10 is ON

LED POWER	Indicates the mother board in ON
LED ALARM	Goes ON in Alarm
LED DISQUALIFICA	Indicates the disqualification active. The alarm relay is inhibited also if the alarm led is ON
LED RISCALDATORI	Indicates the status of heaters. It will be activated if the temperature inside the barrier become below 18°C

CONNECTORS DESCRIPTION AND FUNCTIONALITY

The connector has:

- Supply 10-30Vdc
- Tamper output
- Supply 12-24Vac-dc for heaters on board QUAD-ESA and on the optical
- Alarm relay that can be N.O. or N.C. as set before.
- AND remoted remoto: giving a negative input the system works in AND.
- DISQUALIFICA: NEGATIVE OPEN COLLECTOR in case of fog
- On the card is provided an input for the tamper. In case of absence of that close the input with a jumper

12 RESPONSE TIME ADJUSTMENT

There is a potentiometer to adjust the TIME OF INTERVENTION.

In particular, you can set the barrier for the rapid alert system (cross running) or slow (cross by walk).



By adjusting the potentiometer counterclockwise to increase the trip time up to 500ms. In this condition ensures that the alarm of a person walking through the barrier, with the advantage of excluding the possibility of any false alarms (ex. animals).

Adjusting the potentiometer clockwise decreases the trip time until 50ms. In this condition ensures the alarm of a person crossing the barrier running at maximum speed.

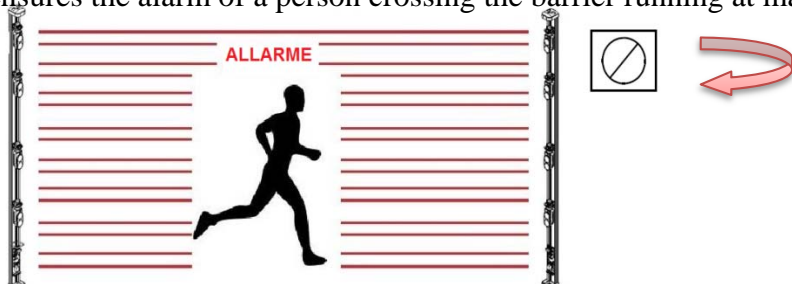

13 TECHNICAL CHARACTERISTICS

MODELS	DUAL SMA	QUAD SMA	ESA SMA
Max range indoor		450 m	
Max range outdoor		100 m	
Min distance		4 m	8 m
Min Heigh of column	35 cm	1 m	1,5 m – 2,0 m
Synchronism		Optic	
Beams total	4 (crossed)	16(crossed)	36 (crossed)
Alimentazione		12Vdc	
Power consumption	Tx 30 mA+Rx 60 mA	Tx 30 mA+Rx 50 mA	Tx 80 mA+Rx 80 mA
Heaters	10W + 10W 24Vac	20W +20W 24Vca Thermostated	30W+30W 24Vca Thermostated

OPERATING TEMPERATURE -25° / +65°.
Available Kit heaters for temperatures up to -50 ° C.

VERTICAL ADJUSTMENT 20°

HORIZONTAL ADJUSTMENT 180°

**DETECTION FUNCTION AND/OR Tx E Rx
ALSO FROM REMOTE**

ALARM RELAY ' NC/NO

TAMPER NC

DISQUALIFICATION OPEN COLLECTOR

LED EXCLUDIBLE

INFRARED Impulsive double lenses 950 nm

PROTECTION DEGREE IP 65

ACCESSORIES FOR WALL MOUNTING

ACCESSORIES FOR POLE MOUNTING